

CPU CIRCUIT BOARD

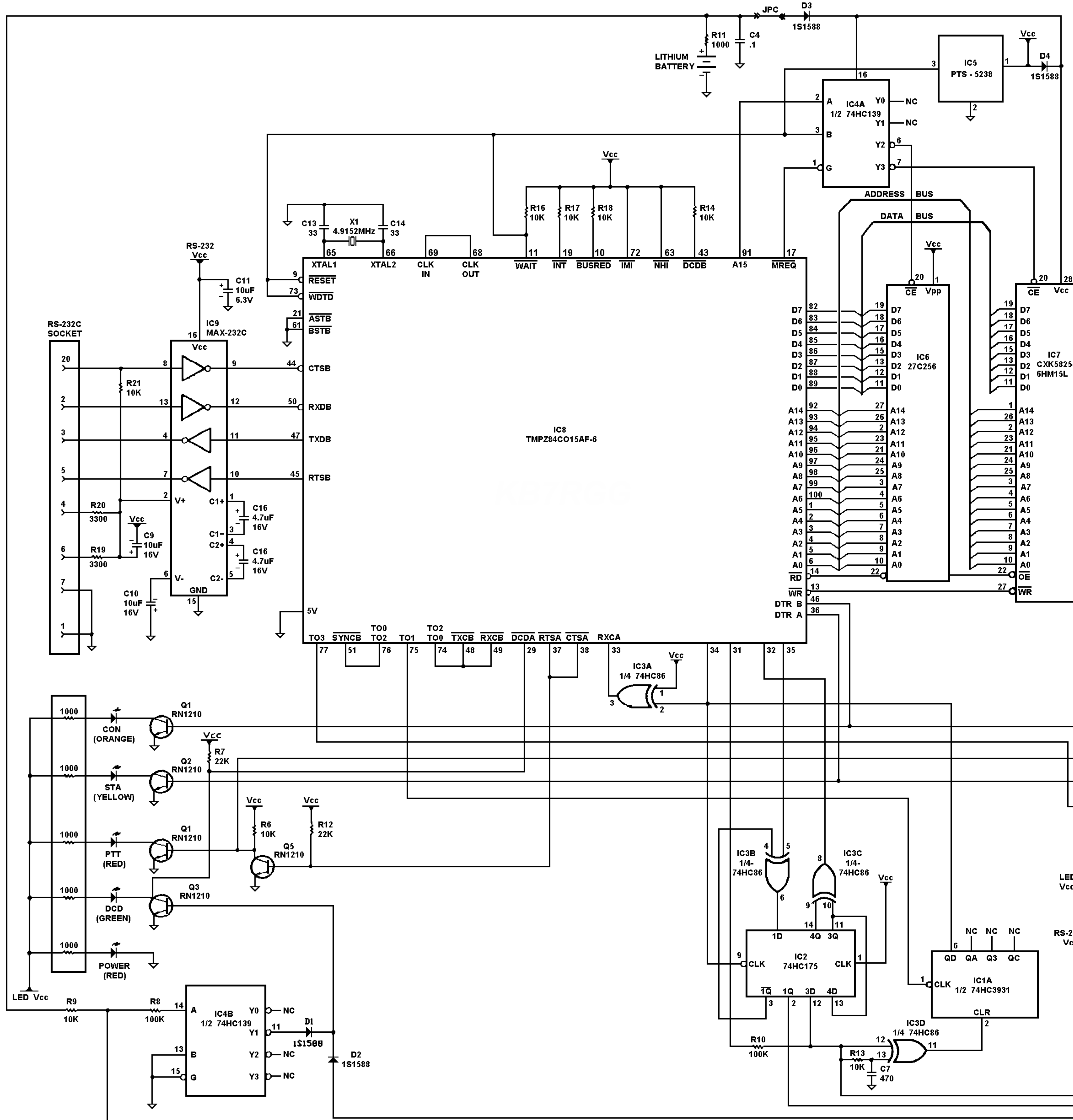

MODEM CIRCUIT BOARD

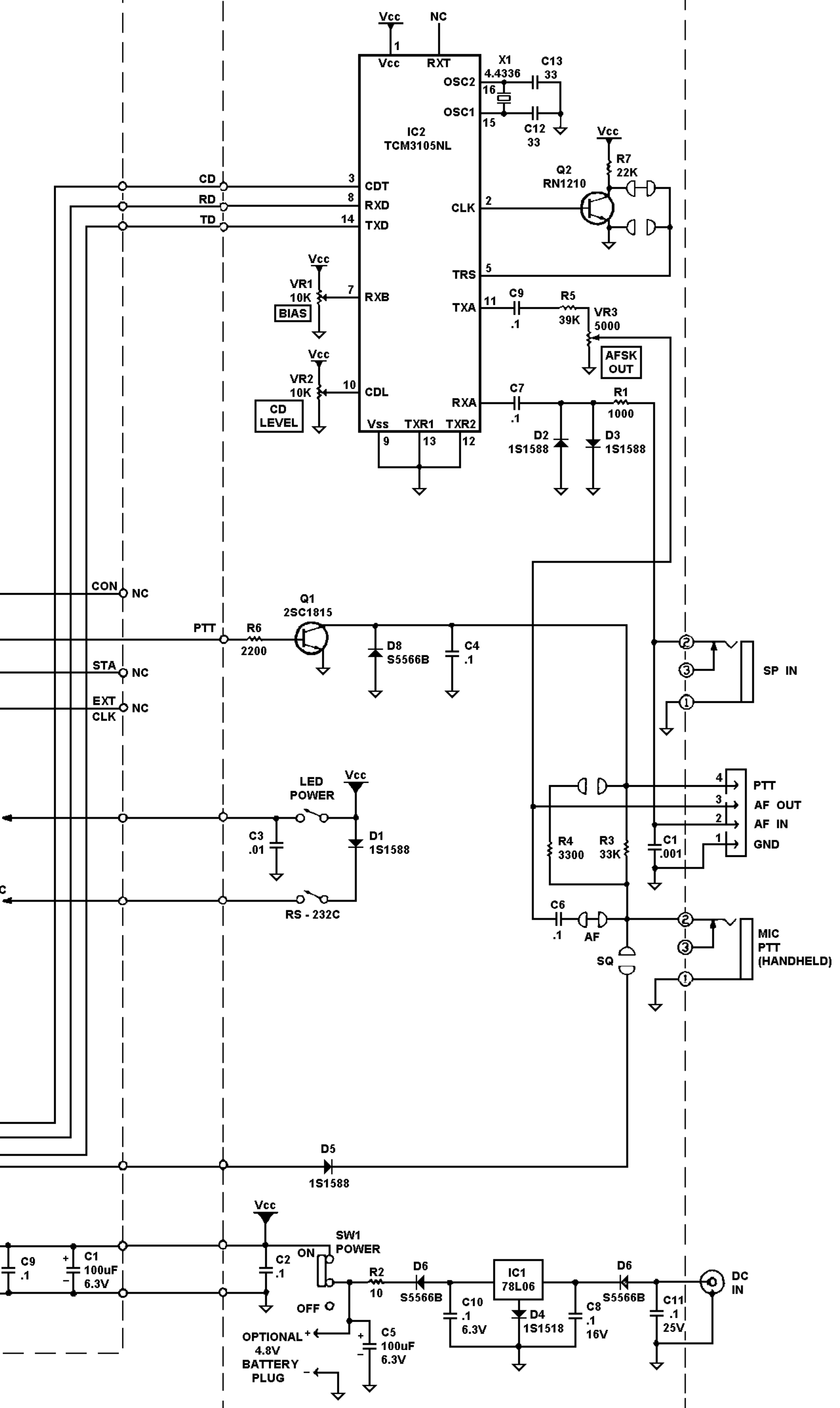

Schematic of the Heath® Pocket Packet® Model HK-21

- NOTES:
1. All resistors are rated at 1/4-watt and have a tolerance of 5% unless otherwise noted. Resistor values are in ohms (k=1000; M=1,000,000).
 2. Capacitor values are in µF (microfarads) unless otherwise noted.
 3. ⚡ This symbol indicates circuit board ground.